

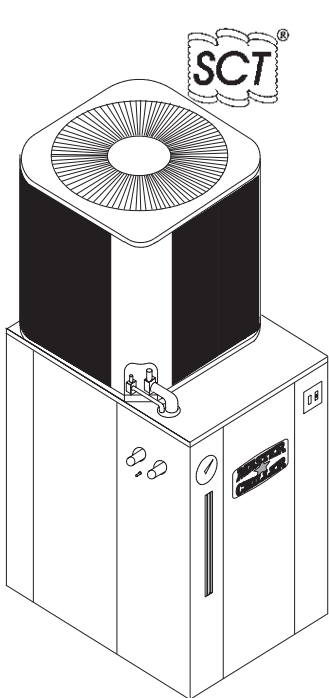

# Product Sheet



2 thru 20 Ton  
Package  
Chillers



**2 thru 5 Ton**

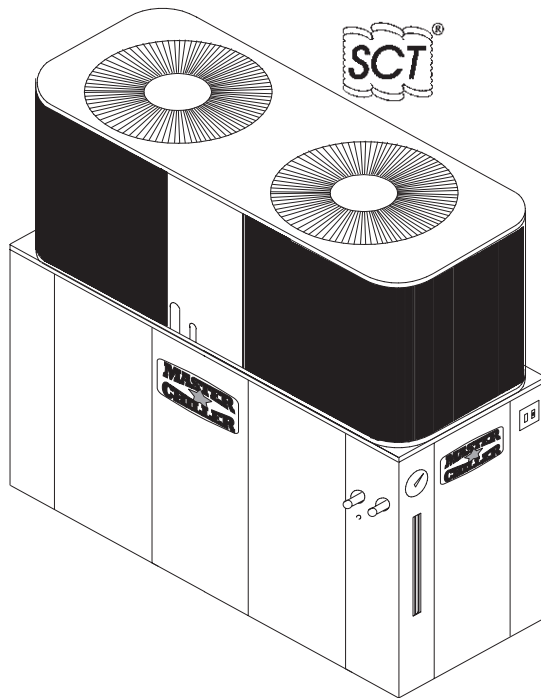

**7½ thru 10 Ton**

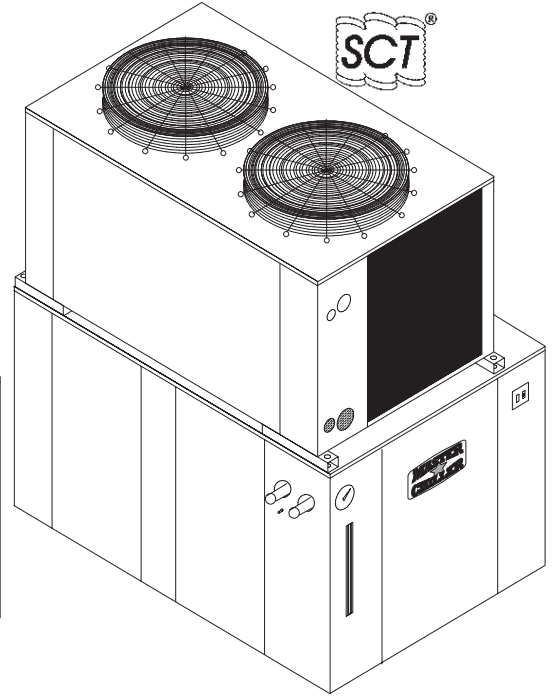

**15 thru 20 Ton**

## STANDARD FEATURES

- Welded angle iron **Powder Coated** frame.
- **Powder Coated Paint Grip**® steel panels.
- On/Off switch and temp. indicator.
- High Efficiency industrial condenser.
- High efficiency American compressor.
- Industrial accumulator.
- Industrial receiver.
- Industrial manual reset high pressure safety.
- Industrial Auto. reset low pressure safety.
- Industrial pump down system.
- Moisture indicating liquid line sight glass.
- R-22, HCFC\* system; ready to run. \*Appr. till yr.2020.
- Covered & Insulated polyethylene tank.
- Tank liquid level indicator/with makeup float valve.
- Efficient **Spirallex Cluster Coil**® evaporator.
- High pressure/volume **GOULDS**® pump.
- Internal liquid system bypass.
- Temperature controlled in tank/**Stores cold liquid.**
- Can chill water & non-flamable/non-corrosive liquids.
- Fan cycling for low ambients down to +10°F.
- Tank, pump, and ref. unit in **One Package.**
- Suitable for inside or outside installation.
- Factory charged and tested under load.
- Single point electrical connection.
- Ready to run, just hook up elec. and liq. lines.

## WARRANTY

- Compressor 5 years.
- All other parts 1 year.
- Labor 1 year.

## OPTIONS

- **Head Pressure** low ambient control to -40°F.
- Digital controls/ remote digital controls.
- Larger pumps.
- Glycol fill port.
- Stainless steel lower cabinet.
- Pump pressure gage.

*Building better Chiller Systems since 1981*

**MASTER CHILLER INC.** 3730 Dividend Dr. Garland, TX. 75042

**1-800-666-5822**

**972-272-0886**

**FAX 972-494-9047**



# Product Information



2 thru 20 Ton  
Package  
Chillers

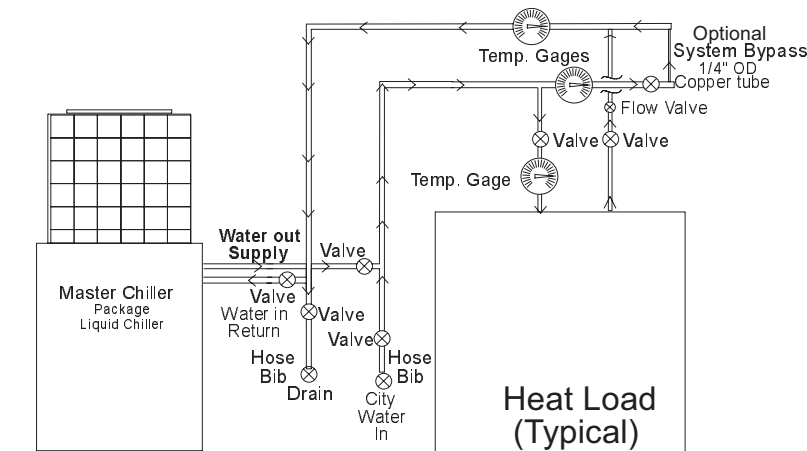

**Package Chillers are factory charged, tested, and ready to run.**  
**One electrical connection, three pipe connections, and the Chiller is installed.**  
**Chillers can be installed inside or outside.\***

**Chillers come standard with fan cycling for operation down to +10°F.\***

**Chillers can be operated down to -40°F with optional low ambient kit.\***

\* Chillers installed in freezing conditions must have Glycol or Antifreeze added to the chilled liquid and capacities will be reduced.

## Simple easy installation

### Specifications

Model #	Nom. Tons	Chiller Electrical	Approx. Amps	Min. Fuse	Unit Dim. L W H	Tank Size	Pump Size	Water IN OUT	Approx. Ship WT.
MCP201	2	208-230/60/1	17.5	22.1	39"x30"x58"	55 Gal.	3/4 Hp	1 1/4" 1"	300
MCP301	3	208-230/60/1	23.0	29.1	39"x30"x64"	55 Gal.	3/4 Hp	1 1/4" 1"	300
MCP303	3	208-230/60/3	16.9	21.3	39"x30"x64"	55 Gal.	3/4 Hp	1 1/4" 1"	300
MCP401	4	208-230/60/1	27.0	34.1	39"x30"x74"	55 Gal.	3/4 Hp	1 1/4" 1"	350
MCP403	4	208-230/60/3	22.1	27.9	39"x30"x74"	55 Gal.	3/4 Hp	1 1/4" 1"	350
MCP501	5	208-230/60/1	34.5	43.6	39"x30"x76"	55 Gal.	3/4 Hp	1 1/4" 1"	400
MCP503	5	208-230/60/3	25.1	31.7	39"x30"x76"	55 Gal.	3/4 Hp	1 1/4" 1"	400
MCP504	5	460/60/3	16.1	20.3	39"x30"x76"	55 Gal.	3/4 Hp	1 1/4" 1"	400
MCP7503	7 1/2	208-230/60/3	42.6	53.8	78"x32"x85"	55 Gal.	1 Hp	1 1/4" 1"	750
MCP7504	7 1/2	460/60/3	26.4	33.4	78"x32"x85"	55 Gal.	1 Hp	1 1/4" 1"	750
MCP1003	10	208-230/60/3	52.6	66.5	78"x32"x85"	55 Gal.	1 Hp	1 1/4" 1"	775
MCP1004	10	460/60/3	30.2	38.2	78"x32"x85"	55 Gal.	1 Hp	1 1/4" 1"	775
MCP1503	15	208-230/60/3	84.3	106.5	77"x52"x85"	112 Gal.	1 1/2 Hp	1 1/2" 1 1/4"	1000
MCP1504	15	460/60/3	43.9	55.5	77"x52"x85"	112 Gal.	1 1/2 Hp	1 1/2" 1 1/4"	1000
MCP2003	20	208-230/60/3	91.9	116.1	77"x52"x85"	112 Gal.	1 1/2 Hp	1 1/2" 1 1/4"	1210
MCP2004	20	460/60/3	48.3	61.0	77"x52"x85"	112 Gal.	1 1/2 Hp	1 1/2" 1 1/4"	1210

Specifications may change without notice.

50cy available in some sizes call **Factory** or **Sales Representative**.

*Building better Chiller Systems since 1981*

**MASTER CHILLER INC.** 3730 Dividend Dr. Garland, TX. 75042

**1-800-666-5822**

**972-272-0886**

**FAX 972-494-9047**